



PURE PLANT OIL AS FUEL

TECHNICAL ASPECTS AND LEGISLATIVE CONTEXT



SUMMARY

- 5 A FUEL WITH A FUTURE
- 6 PURE PLANT OIL: A NEW FUEL?
- 7 THE CURRENT SITUATION. A EUROPEAN OVERVIEW
- 9 EU BIOFUEL MARKET PLACE: LEGISLATIVE FRAMEWORK
- 13 SUSTAINABILITY AND CERTIFICATION
- 15 VERIFICATION OF SUSTAINABILITY FOR FUELS IN AUSTRIA
- 16 THE BASICS OF PURE PLANT OIL PRODUCTION
- 18 CULTIVATIONAL ASPECTS OF OILSEEDS. RAPESEED
- 19 CULTIVATIONAL ASPECTS OF OILSEEDS. SUNFLOWER
- 20 SEED PROCESSING AND OIL PRESSING
- 23 THE PROPER STORAGE OF PURE PLANT OILS
- 25 RAPESEED CAKE AS A FEEDSTUFF FOR FARM LIVESTOCK
- 26 PURE PLANT OIL QUALITY DIN 51605
- 27 PURE PLANT OIL QUALITY AND THE CEN FUEL STANDARD
- 28 OPPORTUNITIES FOR USING PURE PLANT OIL AS A FUEL IN ENGINES
- 31 TECHNICAL SOLUTIONS
- 32 THE ECONOMIC VIABILITY OF TRACTOR CONVERSIONS
- 34 WHERE YOU CAN GET INFORMATION



www

INTRODUCTION

A FUEL WITH A FUTURE

The development of European fuel prices is similar to a route map up Mount Everest where the summit has not been climbed for a long time. Europe, which imports 84% of its crude oil requirement, is in a struggle with the emerging economic giants China and India over the finite oil resources of the world. The never-ending hunger for energy also has an environmental cost. The transport sector is responsible for a large part of European greenhouse gas emissions. From the present perspective, biofuels such as pure plant oil are a commercial alternative offering the possibility of reducing dependence on fossil fuels. The European biofuels directive therefore provides for an increase in the amount of biofuel admixture up to 10% by 2020. In 2009, the proportion of biofuel was about 4%.

Particularly for the agricultural and forestry industries, the use of pure plant oil offers the opportunity to once more attain energy security. In contrast to biodiesel or bioethanol, pure plant oil can be produced without expensive production technology and in a completely autonomous process, in small installations. Where the by-product press cake is used as an animal feedstuff, the natural cycle is completed. Today, strict sustainability criteria assure an environmentally sound production. In building up a domestic protein production industry and reducing the high level of protein feed imports from Brasil and Argentina, as well as protein feed, there is enough pure plant oil remaining which can be profitably used as an agricultural fuel. Pure plant oil is a valuable speciality fuel which, when understood as such, is able to stand up to any ethical discussion on biofuel use.

Our food supply is based on a diminishing energy source. Without fossil fuels, agricultural output would cease and this would be a catastrophe for food policy. This fact is reason enough to promote a sustainable biofuel strategy in Europe. The current legal framework for the use of pure plant oil is very unsatisfactory as it is administered differently in different states. Unitary European standards covering the use, taxation and quality assurance of these fuels are urgently required. The use of pure plant oil fuel relieves our climate and at the same time provides for a sustainable protein feed supply and energy source in the European agricultural and forestry industries.

Thomas Loibnegger

Chamber of Agriculture of Styria, Graz (Austria)

Project Coordinator

PURE PLANT OIL A NEW FUEL?

JOSEF BREINESBERGER

AGRAR PLUS GmbH
St. Pölten (Austria)

The idea of using natural pure plant oils as a fuel for engines is certainly not new, but is as old as the diesel engine itself. When Rudolf Diesel invented the diesel engine over 100 years ago, he operated his first engines with pure plant oil.

In light of the current developments in the oil industry and the associated oversupply of low-priced oil products, it will soon be the case that pure plant oils will no longer be competitive.

It is only in times of crisis such as during the two world wars or the energy crisis of the early 1970s that the feasibility of using pure plant oils comes to the forefront but when oil imports start to recover, the idea is dropped.

There is no shortage of reasons for using pure plant oil as a fuel:

ADVANTAGES FOR THE ENVIRONMENT

- The energetic use of biomass causes no additional output of CO₂ as the growing crops absorb almost the same quantity of CO₂ that they release on combustion.
- Pure plant oils have a good level of environmental sustainability, for example, natural pure plant oils in Germany are rated as water hazard classification 0.

ADVANTAGES FOR THE REGION

- Pure plant oils are mainly produced on a regional basis. This leads to the creation of additional jobs as well as

regional value creation and business activity.

- The cultivation of renewable raw materials represents an additional source of income within agriculture. It is also of great advantage for farmers to produce the fuel they require on their own land.

INDEPENDENCE

- For how much longer will fossil fuel resources last? Current analyses made by the International Energy Agency show that in the future, demand for energy will increase strongly. The reasons for this are on the one hand, unused cost-saving opportunities through energy efficiency measures in the industrial countries, and on the other, the rapid growth of the energy requirement of emerging economies such as India and China.
- The use of pure plant oil as a fuel brings independence from the large oil-exporting states, countries which often lie in politically unstable regions. Furthermore, it brings independence from the oil multinationals.

PROFITABILITY

- The higher the price of diesel, the greater will be the profitability of the use of pure plant oil as a fuel. At present, oil prices are the highest they have ever been.



THE CURRENT SITUATION

A EUROPEAN OVERVIEW

HEIN ABERSON

Solaroil Systems

MS Boijl (the Netherlands)

In the year 2007, more than a million tonnes of pure plant oil were produced from about 600 oil mills in Europe, partially replacing the demand for fossil diesel fuel. At least 40,000 heavy goods vehicles, cars, tractors, ships and locomotives were operated with 100% pure plant oil leading to a reduction in CO₂ emissions of about 2.6 million tonnes!

This development followed the requirement of the European Commission that the member states implement the guidelines of the European Union and actively reduce CO₂ emis-

sions in the transport sector as well as achieve a greater independence from the import of fossil fuels. A side-effect of this was the creation of more than 10,000 new jobs as well as significant technical advances in this new sector. In a joint project, the transport and agricultural sectors have undertaken the first steps in the direction of an economy based on biofuels and made a contribution to the principles introduced in Europe of economic independence.

Pure plant oil is produced mainly from rapeseed and sunflower crops cultivated in Europe. The yellow fields of rapeseed are the first crops to appear on the agricultural landscape, a paradise for insects and wildlife. The cultivation of rapeseed has flourished since the start of 2000 and in the meantime has received further impetus as an animal feedstuff. Rapeseed is cultivated within a crop rotation system and is planted before cereal crops. Rape cultivation improves the soil quality by introducing 8 tonnes of carbon per hectare. The processing of the rapeseed takes place mainly in decentralised rural oil mills. The press cake offers Europe its own source of agricultural protein. As a co-product, about 30% pure plant oil is produced.

Some EU member states which have introduced a tax-free status for pure plant oil fuel have seen an unexpected success in the use of such fuel and





other 100% biofuels (i.e. biodiesel/ ethanol).

The imposition of taxation on oilseed and the rise in prices represents a major setback for the large number of biofuel initiatives involving small and medium-sized European enterprises and has created a huge economic challenge in the competition with fossil fuels. These unfavourable framework conditions have led to the situation whereby many European initiatives were given up, resulting in the closure and dismantlement of the production facilities for biofuels, the wastage of investment funds and the loss of jobs, innovation and a great deal of know-how costing billions.

Pure plant oil represents above all for rural areas, and particularly for the whole agricultural and food production sector, a possible option to make a significant contribution to European objectives specified in the directives on renewable energy - 2009/28/EC and fuel quality - 2009/30/EC.

We performed a basic survey among the main national representatives (mainly sectoral associations) in some EU Member States to investigate the general situation on the use of PPO as a transport fuel in different industries and the relative financial status up to the present (June 2011). These are the main results which are here reported in the following tables.

IS PPO ALLOWED IN THE AGRICULTURAL SECTOR AS FUEL FOR MACHINERY (E.G. TRACTORS, HARVESTING, CHIPPERS) ?

Germany, Austria, Finland, Poland, Belgium, Slovenia, Sweden, Netherlands, Bulgaria	Yes
Italy	No

IS PPO ALLOWED IN PRIVATE CARS/VEHICLES AS FUEL?

Germany, Austria, Poland, Belgium, Slovenia, Sweden, Netherlands, Bulgaria	Yes
Italy	No
Finland	Still uncertain legislative framework

IS PPO ALLOWED AS FUEL FOR ELECTRICITY PRODUCTION?

Germany, Austria, Poland, Belgium, Slovenia, Sweden, Netherlands, Italy	Yes
Bulgaria, Finland	Still uncertain legislative framework (Quality)

EU BIOFUEL MARKET PLACE LEGISLATIVE FRAMEWORK

ELISEO ANTONINI

AIEL Italian Agriforestry Energy Association
Legnaro/Padova (Italy)

REENT MARTENS

3N-Kompetenzzentrum e.V.
Werlte (Germany)

Fuel filling station in Germany (April 2009), supplying pure rapeseed oil as well as standard fossil fuels including methane and propane. Road sign: 'Denial of Access' to the market appears to apply only to pure plant oils.



Around one third of the EU-27 primary energy consumption is associated with the transport sector and the share of biofuels was in 2009 12 Mtoe (4%) which is a long way from the set target of 18 Mtoe.

Pure plant oil accounts for about 0.9% of transport fuel used in 2009, about 120,000 tonnes in total (AEBIOM, 2011). In the German market alone for 2005 - 2007, about 300,000 tonnes were produced (TFZ Bavaria, 2007). This was used mainly in the agricultural and forestry sectors.

STATE OF THE ART

The EU Commission has the task of carrying out a progress report on the development of renewable energies to meet the 2020 target. Here are some of the results taken from documents assessing the situation at the end of 2010.

Since the release of directive 2003/30/CE the first task that Member States had to undertake was the regulation of the duties and taxes on the biofuels. The European Parliament (resolution of 18 June 1998) called for an increase in the market share of biofuels over five years through a package of measures, including tax exemption, financial assistance for the processing industry and the establishment of a compulsory rate of biofuels production for oil companies.

According to Article 16 of the DIR 2003/96/EC, Member States are authorised to apply an exemption or a reduce

rate of taxation on the taxable product, referred to as energy product in Article 2 of the Directive, i.e. pure biofuel or biofuels blended with minerals oils, which are motor fuels. However, pursuant to Article 16 taxation measures have to be limited in time and may not be applied for a period of more than six consecutive years. This period may be renewed.

After some year (2011) in the report to the European Parliament and the Council, the Commission's analysis indicates that the highest biofuel market shares are usually achieved by those Member States that have obligations in place, combined with tax incentives (Germany, Slovakia, France).

Currently, 19 Member State have obligations in place. If no obligations are in place, substantial tax incentives are required to reach the the target biofuel market shares.

TARGET AND SHARE

Under the Directive 2009/28/EC of 23 April 2009 on the promotion of the use of energy from renewable sources this share rises to a minimum 10% in every Member State in 2020. Whether it is electricity or hydrogen from renewable energy sources, or 1st or 2nd generation biofuels, there is an urgent need to ensure we meet this goal. The Directive also aims to ensure that as we expand the use of biofuels in the EU we use only sustainable biofuels, which generate a clear and net GHG saving and have no

negative impact on biodiversity and land use.

In 2008 the EU share of renewable energy in transport was 3.5%, while it was 2.6% the year before. For 2009, preliminary data indicate further growth in the sector, with the biofuels share reaching 4% of the total fuel consumption in transport.

In 2008, 10.1 Mtoe of biofuels were consumed in road transport, representing 3.5% of all petroleum products consumed in road transport (293 Mtoe).

In 2009 (AEBIOM Statistic, 2011) biodiesel remained the most frequently used biofuel in the EU accounting for 79.5% (9.5 Mtoe) of the total biofuels consumed, and while bioethanol makes 19.3% (2.3 Mtoe) and the remaining 1.2% includes other biofuels such pure plant oil (0.9%) and as biomethane (0.3%) used in a limited number of Member States (e.g. Germany). The share of PPO, even good statistic are nor available, is rapidly decreasing. In the most important market, Germany, the sales of pure plant oil fuel dropped from 100,000 tonnes in 2009 to a only 61,000 tonnes in 2010, it means 0.1 % of the total energy content (BWA Report 2011 DIR 2003/30/EU).

IMPORT AND EXPORT OF BIOFUELS

In 2007, around 15% of the biofuels consumed in the EU were imported; the previous year it was 25%. At the same time, export shares rose from 7% (2007) to 10% (2008), so that the net import in 2008 was about 15%.

THE CASE HISTORY: GERMANY

Germany was the leading market for pure plant oil until August 2006. A progressive tax was introduced at the beginning of 2008 which will increase until the beginning of 2012 when it will be set at 45 c€/litre (plus VAT).

By March 2007, there were about 577 decentralised oil mills in Germany processing about one million tonnes of rapeseed to produce approximately 330,000 t of rapeseed oil and about 650,000 t of cake, which is very suitable as a protein base in animal feedstuffs.

These oil mills were of small to medium capacity, as shown in the tables below which are based on a national survey carried out in Germany over a period from the end of 2006 to the beginning of 2007.

The following figures are for the 577 working mills in Germany in March 2007.

Uhl, A.; Haas, R.; Remmele, E. (2007): "Befragung von Betreibern dezentraler Ölsaatenverarbeitungsanlagen" Berichte aus dem TFZ, Nr. 15.

Mills capacity	
of 50 kg seed/hours	40%
from 50 to 500 kg seed/hours	43%
Over 500 kg seed/hours capacity	16%

Seed production radius from the decentralized oil mills

Seed is coming from	
Produced on own land	13%
< 20 km radius	55%
20-50 km radius	20%

Delivery radius for oil produced in decentralised mills

Self-consumption	11%
< 25 km radius	25%
25-50 km radius	25%
> 50 km radius	36%

Radius of delivering and use of the produced rapeseed cake in the decentralized oil mills

Self-consumption	11%
< 25 km radius	54%
20-50 km radius	16%

Source: Remmele, E. (2007): "Handbuch. Herstellung von Rapsölkraftstoff in dezentralen Ölgewinnungsanlagen" Gülzow: FNR e.V.

For around 50% of the oil mills, the main activity was the production of biofuels using pure plant oil as the basis of biodiesel production. For 20%, the main activity was the production of edible oil and 17% focused on producing cake for animal feed.

After the introduction of progressive taxation, most of the oil mills (60%) reduced their activities to a level supportable because of the production of rapeseed cake for livestock, but oil mills still have problems selling oil to the market because of the rising price of raw materials.

FISCAL CURRENT STATUS IN SOME EU COUNTRIES

As many national and regional projects have shown, the use PPO as fuel in combustion engine is technically possible and suitable.

The main barriers are represented by the legislative and fiscal framework which are restraining the use of it.

Commission Regulation (EC) N° 794/2004 implementing Council regulation (EC) N° 659/1999 lays down detailed rules for the application of Article 88 of the EG treaty. In particular the Article 2 of the Commission Regulation notifications of a new aid shall be made on the notifications form set out in Part I of Annex I of these regulations. This is in order to inform the Commission

of taxation measures such as tax exemptions, tax reduction, tax differentiation and tax refund within the meaning of Directive 2003/96/EC.

According to Article 16 of the DIR 2003/96/EC, Member States are authorised to apply an exemption or a reduced rate of taxation on the taxable product, referred to as energy product in Article 2 of the Directive, i.e. pure biofuel or biofuels blended with minerals oils, which are motor fuels.

However, pursuant to Article 16 taxation measures have to be limited in time and may not be applied for a period of more than six consecutive years.

This period may be renewed.



The working group questioned partners and some national associations about the fiscal framework under which PPO is currently used as a biofuel for transport purposes.

PPO: FISCAL FRAMEWORK FOR TRANSPORT PURPOSES

Germany	<p>In 2006, a progressive tax was introduced with the Energy Tax law (8 c€/litre) until 2012 (45 c€/litre). For pure plant oils complying with DIN 51605: 1st January 2011 - 18.46 c€/litre 1st January 2012 - 44.90 c€/litre</p> <p>Pure plant oils which do not comply DIN 51605 are fully taxed. The use of pure plant oil and also biodiesel as fuel in the agricultural sector is tax free. VAT: 7% refined rapeseed oil, and even then, if the product is used as fuel but not a mixture of rapeseed oil and diesel fuel.</p>
Austria	<p>PPO used: taxation 0.0 € PPO blended with fossil diesel: whole taxation on the mixture - 0.347 €/litre blended in biodiesel - 0.375 €/litre blended in fossil diesel</p> <p>In the case of refuelling through the end-user in two steps: first refuelling with diesel, second refuelling with PPO: no taxation on the PPO Where the end-user uses a filling nozzle which directly blends the two fuels (diesel and PPO) direct by the filling nozzle: no taxation on the PPO VAT: 10%</p>
France	<p>Self-consumption for farmers: VAT 0% - Domestic consumption tax 0% (TIC) Using in captive fleet for local authorities with official authorization: VAT 19,6% Domestic consumption tax (TIC): 31.84 €/100 l in 2010 34.84 €/100 l in 2011 For Diesel cars: VAT 19,6% - Domestic consumption tax (TIC) 42,84 €/ 100 l</p>

Italy	<ul style="list-style-type: none"> - Farmer, self-production and self-consumption: Tax 189 €/1000 litre – VAT: 0% - Farmer sells a part of his self-produced PPO: Tax 189 €/1000 litre and applies 20% VAT - Farmer buys on the local market and use in his tractors the PPO producers pay tax: 189 €/1000 litre and the farmer pays: 21% VAT <p>This is the case also for the non-agricultural end-user</p>
Belgium	<p>PPO is tax-free until the end of 2011 If a new fiscal framework is approved by the EC, it will be under different conditions</p> <ul style="list-style-type: none"> - PPO should be produced by farmers and their associations - Farmers must use their own oil-seeds - Farmers sell PPO directly to the end-users <p>VAT: n.a.</p>
Finland	<p>Taxation for farmers: 0,1605 €/litre</p> <ul style="list-style-type: none"> - If PPO is used for vehicles, over the PPO's price (\pm 0,80 €/litre) the taxation is the following: - 0,2814 €/litre → Carbon dioxide tax - 0,1214 €/litre → Strategic stockpile - 0,0035 €/litre → fee <p>TOTAL TAX: 0,4063 €/litre (Energy Content Tax) FINAL PRICE: 1,2063 €/litre</p>
Netherlands	<p>By the end of 2010 the free taxation framework ended. VAT: 19% Mineraloil taxes: 0,41 €/liter plus 19% VAT</p>
Denmark	<p>The fuel tax on PPO and any other biofuel substituting diesel is 9,27 €/GJ. It is 0,315 €/liter of PPO For sulfur free diesel the fuel tax is 0,332 €/liter, and additionally are paid a CO₂ tax 0,055 €/liter: totally 0,387 €/liter Both fuels and all taxes are subject to 25% VAT</p>
United Kingdom	<p>PPO is taxed at the same rate as all normal fuels and all biofuels except those from waste oil. The rate is 56.12 pence per litre. Waste oil derived biofuels are taxed at 36.12 pence per litre until April 2012 when this will be reviewed.</p>
Poland	<p>Farmers: tax free Other end-users: untill 30 April 2011 there was a tax reduction (2,5 €/t less than the fossil fuels). Until that period the taxation is the same for fossil fuels VAT: n.a.</p>
Sweden	<p>There are no taxes on PPO as fuels even if it is mixed. VAT: 25%</p>
Slovenia	<p>Taxation is the same as for fossil fuels, which was (2010) about 430,21 €/1000 litre VAT: 20% Farmers can have duties returned, under specific national regulations, at the end of the year. The same for some companies using PPO as fuels for commercial purpose.</p>

SUSTAINABILITY AND CERTIFICATION

MARIE-LUISE ROTTMANN-MEYER REENT MARTENS

3N-Kompetenzzentrum e.V.
Werlte (Germany)

“In the years to come, biofuels are the main alternative to petrol and diesel used in transport, which produces more than 20% of the greenhouse gas emissions in the European Union. We have to ensure that the biofuels used are also sustainable. Our certification scheme is the most stringent in the world and will make sure that our biofuels meet the highest environmental standards. It will have positive effects also on other regions as it covers imported biofuels.” - Günther Oettinger, EU Energy Commissioner.
(Press release IP/10/711, 10/06/2010).

This renewable energy directive of December 2010 includes the introduction of voluntary rules for the certification of the sustainability of biofuels and sets out the general conditions which have to be met in order to be recognized by the EU. The main criterion deals with the degree of transparency of the production and distribution chain from the farmer via the mills and dealers to the filling stations.

The production of biofuels from land with a high nature conservation value (virgin forest, areas with high carbon stocks, wetlands and moors) will no longer be possible in the future. So, for example, the conversion of woodlands into oil palm plantations would not fulfill these sustainability requirements. Furthermore, only biofuels with a high greenhouse gas saving potential can be considered in national objectives and must have a potential to achieve greenhouse gas savings of at least 35% compared to fossil fuels.

This level will increase to 50% in 2017 and 60% in 2018 for biofuels from new installations.

The following certification systems have been acknowledged 2011 by the European Commission.

- ISCC (German (government financed) scheme covering all types of biofuels)
- Bonsucro EU (Roundtable initiative for sugarcane based biofuels, focus on Brazil)
- RTRS EU RED (Roundtable initiative for soy based biofuels, focus on Argentina and Brazil)
- RSB EU RED (Roundtable initiative covering all types of biofuels)
- 2BSvs (French industry scheme covering all types of biofuels)
- RSBA (Industry scheme for Abengoa covering their supply chain)
- Greenergy (Industry scheme for green energy covering sugar cane ethanol from Brazil).

PROOF OF SUSTAINABILITY OF FUELS IN GERMANY

Germany was the first EU state to implement the EU Directive in 1 January 2011 in national legislation with the biofuel sustainability ordinance. The various documentary and certification provisions dealing with the sustainability certification for biofuels and liquid biomass (the biofuel and biomass ordinances) are regulated through the two existing approved certification systems - REDcert and ISCC.



- carbon stocks (e.g. moorland, wetland),
- no use of biomass from land which was classed as peatland on 1 January 2008,
- biomass cultivation is to comply with good practice (cross compliance – sustainable agricultural methods),
- the greenhouse gas reduction potential is 35%.

After the harvest of 2010, in consideration of compliance with the legal requirements of the Federal Control of Pollution Act (BlmSch), that is, the allowance of biofuels in the biofuel quota and their tax benefits, only biofuels are considered which were produced with verifiably sustainable methods and can demonstrate a minimum greenhouse gas reduction potential. Proof of sustainable biomass production must be provided through a relevant certification system. Additionally, compliance with requirements on the application of a mass balance system along the production and supply chain must be documented. Information about this is provided in 'Guidelines on sustainable biomass production' issued by the German Federal Agency for Agriculture and Food (BLE) (www.ble.de). The guidelines can be downloaded from the BLE homepage under 'publications'.

Until now the International Sustainability and Carbon Certification system (ISCC), the certification system REDcert and Roundtable on sustainable biofuels - RSB are certificated in Germany.

The sustainability ordinance regulates the following:

- requirements for the sustainable production of biomass
- proof of origin of sustainable biomass
- certification system and certifying bodies.

Main requirements of the sustainability ordinance:

- no use of biomass from land with a high conservation value (e.g. grassland with high biodiversity, nature protection areas),
- no use of biomass from land with high

VERIFICATION OF SUSTAINABILITY FOR FUELS IN AUSTRIA

JOSEF BREINESBERGER
AGRAR PLUS GmbH
St. Pölten (Austria)

On the basis of the EU Directive 2009/29/EC on promoting the use of energy from renewable resources, Austria has set up a national monitoring and control system. The Federal Law Gazette II 250/2010 (agricultural materials for transport biofuels and other liquid biofuels), the Agrarmarkt Austria (AMA) is empowered to control and monitor raw materials production, trading and processing. Consequently, the enterprises involved are required to register with the AMA. As opposed to the wholesale buyers, the farmers have to state in writing that their goods meet the sustainability criteria. The AMA can make relevant checks on this using the

System (IACS). Imported goods have to show relevant proof of sustainability. Foreign control systems must be approved by the AMA.

The Federal Environment Agency (UBA) is responsible for the monitoring of sustainably produced transport fuels. This is regulated by the fuel ordinance. Fuel producers and traders must be registered with the UBA. The UBA has developed a certification system which confirms the sustainability of the biofuel. The issuing of certificates and the biofuel producers are monitored by the UBA.

The running costs of both organisations are covered by the regulated market participants.



THE BASICS OF PURE PLANT OIL PRODUCTION

JOSEF RATHBAUER

BLT - Biomass | Logistics | Technology
Francisco Josephinum
Wieselburg (Austria)

PROPERTIES AND POTENTIALS OF PURE PLANT OILS

Chemically, fats and fatty oils, also known as triglycerides, consist of glycerol and three fatty acids. The fatty acids can have a simple or double bond between the carbon atoms.

When there is one double bond in the carbon chain of the fatty acid, it is known as an unsaturated fatty acid, and where there are several double bonds, as a polyunsaturated fatty acid.

The fatty acids found in an oilseed are largely genetically determined and the distribution is known as the fatty acid composition. The structure of the fatty acids has a considerable effect on the physical properties of the oil. In fig. 1, a triglyceride molecule is shown schematically.

In table 1, the fatty acid profile of 4 different pure plant oils is shown. The greater the proportion of unsaturated fatty acids, the greater is the iodine value. Oils

with a high iodine value are not in principle unsuitable as a fuel, but are classified as having a more 'reactive nature' as the double bonds break more easily.

In the 1990s in FJ-BLT, long-term tests were carried out on a one-cylinder engine using different types of biodiesel with iodine values from 100 to 180 [g iodine/100g oil]. It was established that the higher the iodine value, the higher was the degree of fouling on the piston ring. From the present perspective, therefore, the use of pure cameline oil (iodine value 160) as a fuel is not to be recommended. The marketing of pure plant oils with an iodine number over 125 would be in conflict with the threshold value laid down in DIN 51605.

Characteristic properties such as density, flash point and calorific value are shown to have only minor differences for the various plant oils.

Most of the experience gained in the use of pure plant oil as a fuel is with rapeseed. The cultivation of sunflower as an oil seed is finding growing interest mainly in the Mediterranean and East European countries.

The following numbers were taken from the FAO database which contains data about the various field crops. Since 1980, the area of land used for oilseed cultivation in EU countries has increased from almost 7 million ha to more than 16 million ha in 2009. 40% of the area in cultivation is for rapeseed, 30% for olives, 24% for sunflowers and only 1.9% for

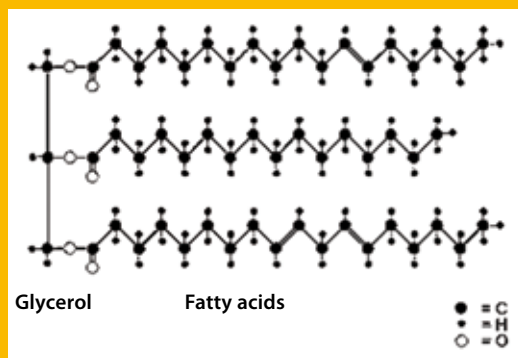

Fig 1 Schematic representation of a triglyceride (Source: Widmann 1999)

Fatty acid [%]		Rapeseed	Sunflower		Camelina
			normal varieties	HO varieties	
16:0	Palmitic acid	3.2 – 5.0	6.4	<4	5.1
18:0	Stearic acid	1.0 – 2.5	1.3	<2	2.2
18:1	Oleic acid	52.6 – 63.2	39	>90	14.0
18:2	Linoleic acid	20.7 – 28.1	47	<3	17.4
18:3	Linolenic acid	10.1 – 15.5	---	---	40.1
20:0	Arachidic acid	---	4	---	1.3
20:1	Eicosatrienic acid	---	---	---	13.4
22:1	Erucic acid	0.0 – 1.7	---	---	3.1
	Other	---	2.3	<2	3.4
	Iodine No. [g/ 100g]	100 – 120	135	95	160

Table 1 Fatty acid composition of different oils (Source: BLT)

soya. The dominance of rapeseed is even clearer when one considers the production quantities. In 2009, the total oilseed harvest in all EU countries amounted to about 42.5 million tonnes. Half of this - 21.4 m.t. was rapeseed followed by olives with 12.5 m.t. and sunflower seeds with almost 7 m.t. With a yield of 840,000 tonnes, soya beans made up 2% of the total oilseed harvest.

From the cultivation and yield figures for the EU countries, it can be deduced that with regard to fuel use, rapeseed will continue to be important in the future and in the Mediterranean and East European countries, sunflower oil will also be significant.



CULTIVATIONAL ASPECTS OF OILSEEDS

RAPSEED (*BRASSICA NAPUS L. VAR. NAPUS*)

GESCHE RIECKMANN

Landwirtschaftskammer Niedersachsen
Hannover (Germany)

REENT MARTENS

3N-Kompetenzzentrum e.V.
Werlte (Germany)

Rapeseed counts as hardly any other crop as the renewable resource par excellence. Rapeseed has been grown as an agricultural crop since the 16th century. As well as its use as a cooking oil, it is also used as an energy source, mainly in the production of biodiesel and as a raw material in the chemical industry. Erucic acid derived from rapeseed is processed to make surfactants, softeners, wetting agents and emulsifiers.

The most important, efficient and best-adapted oil plant is rapeseed. The average winter rapeseed yield lies between 2.0 - 4.0 t/ha. Approximately one third of the harvest amount makes up the oil yield. Summer rapeseed has a lower yield of between 1.5 - 2.5 t/ha.

The most important fatty acid, as a fuel and for the chemical industry, is oleic acid (C18:1 - fatty acid) in rapeseed oil.

The oil content of rapeseed is affected by the variety, location, stage of crop maturity and the weather conditions during the growing phase (temperature sum). Other important factors include harvest time, height of growth, lodging resistance and susceptibility to disease (phoma, sclerotinia).

As well as the seeds with their high oil content, an important byproduct used as an animal feed is rape groats with a protein content of about 35%.

Rapeseed should be cultivated in the crop rotation only every 3 to 4 years. It is best following crops which promote plant breakdown and which mature quickly such as early potatoes, peas, forage, green fallow or winter barley. As a rule, rapeseed is grown after winter barley and also after winter wheat (the latter best only with early harvesting). In close cereal crop rotations, the positive previous crop effect of the leafy rapeseed needs to be considered. When cultivating high erucic acid varieties, care should be taken to ensure variety purity (separate crop rotation and storage is necessary).

The cultivation of rapeseed for industrial purposes is not different from cultivation for consumption with respect to the production technology. Where the rapeseed oil is produced in decentralised oil mills, the harvest time of the seeds has to be a consideration when the intended use is as a fuel. If there is a high level of unripe seeds, the oil will have a high content of phosphorus, calcium and magnesium and also a high acid value. This increases the danger of fouling in the engine during combustion. In fully-matured seeds, the levels of these substances and the acid value are both lower and this reduces the risk of fouling and corrosion.



CULTIVATIONAL ASPECTS OF OILSEEDS

SUNFLOWER (*HELIANTHUS ANNUUS L.*)

ELISEO ANTONINI
VALTER FRANCESCATO

AIEL Italian Agriforestry Energy Association
Legnaro/Padova (Italy)

Sunflower is an annual plant with a spring-summer cycle and which grows in fertile, moist, well-drained soil with a lot of mulch. It is a typical renewal plant with a 110 - 145 day cycle from the middle of March until the end of September. Seeds are optimally planted 75 cm apart (8 - 9 seeds per m² to give 7 - 8 plants each m²), but in commercial planting, seeds are typically planted 45 cm apart and 2.5 cm deep.

Sunflower responds well to the nitrogen inputs, especially during the early growth phase, but shows a low efficiency in nitrogen utilisation.

It is good at using the nitrogen reserve in the soil.

In Italy, PPO is mainly produced from rapeseed and there is a growing market in sunflower seeds. Sunflower is tradition-

ally grown in the central regions, typically for the food industries. The main growing areas are Tuscany, Marche Lazio regions, where it reaches a yield of about 3.0-3.5 t/ha/y.

Field trials were carried out in 2011 in Italy, which gave the following results. For the first time, the average yields of the 10 varieties high in oleic acid were higher than the conventional varieties (3.47 t/ha/y for seed and 1.38 t/ha for oil, compared to 3.37 t/ha/y and 1.33 t/ha respectively). The sunflower varieties which were evaluated and showed productive reliability are NK Camen and Doriana. The varieties Mas 84.E and Mas 83.R still need to be tested to confirm their potential. In some tests, NK Camen achieved yields of 4.1 t/ha/y and an oil output of about 45%, that is, about 17.6 t/ha for dry matter.

The main EU countries which produce sunflower seeds are France, Bulgaria, Romania, Hungary and Italy, totalling 6.5 Mt (FAO 2009). The largest producers nearest to the EU are: Russian Federation and Ukraine (13 Mt), followed by Turkey, Serbia and Moldova (2 Mt).



SEED PROCESSING AND OIL PRESSING

EDGAR REMMELE

Technologie- Förderungszentrum (TFZ)
im Kompetenzzentrum für
Nachwachsende Rohstoffe
Straubing (Germany)

Oil seeds can be processed to produce pure plant oil in both industrial oil mills (central mills, large installations) where the capacity is up to 4000 tonnes per day of oilseed, and in decentralised small installations (decentralised oil mills, fig. 1) with processing capacities between 0.5 - 25 tonnes per day (in individual cases, up to 250 t/d). The two processes are quite different in their complexity and there are differences in the use of solvents, other chemicals and water as well as the production of waste water and other waste materials. And not least, there are differences between the two types of process in the oil yield and therefore in the residual solid content of the press cake or extraction meal.

As a rule, centralised oil mills (fig. 2) produce a fully-refined pure plant oil which is hot-pressed and extracted using solvents, while in decentralised installations, careful oilseed processing is used to produce so-called cold-pressed pure plant oil which does not require the conventional refinery processes (degumming, deacidification, bleaching, deodorisation). Therefore, in decentralised oilseed processing, the quality of the rapeseed, the system of pressing and the oil purification (separation of solid and liquid components) have a big influence on the oil quality. In order to achieve calcium, phosphorus and magnesium contents less than 1mg/kg in the pure plant oil fuel, it is necessary to subject the cold-pressed oil to further

processing. Here, the pure plant oil is treated with sorptive additives or citric acid, conditioned and filtered.

It is particularly important in decentralised oil mills that there is a functioning quality management system in place. The objective is to avoid or minimise any negative influences on the quality of the rapeseed oil fuel, starting with the rapeseed itself and including the production and storage of the resulting fuel and the subsequent delivery system. A rapeseed which is suitable for the production of rapeseed oil fuel is characterised by its full ripeness, absence of growths, a low proportion of broken grain and a low level of foreign materials. The oilseed processing should be carried out in such a way as to prevent the transfer of undesirable contaminants (such as calcium, phosphorus and magnesium) to the product. The solids which are still in the oil after pressing are removed in a minimum of two filtrations. Also at this stage of the process, contaminants and precipitates (such as gums) are removed. And not least, a quality-controlled system of storage must be in place to ensure that the customer receives a fuel which complies with the provisions of DIN 51605 or the pre-standard DIN 51623.

PURE PLANT OIL STORAGE

Care must be taken when storing pure plant oil that oxidation, hydrolysis, polymerisation and enzymatic degradation are all avoided. It is therefore necessary

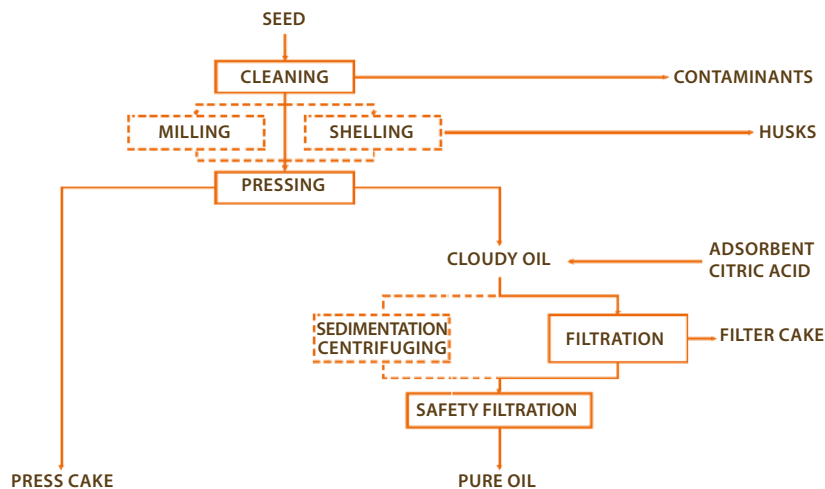
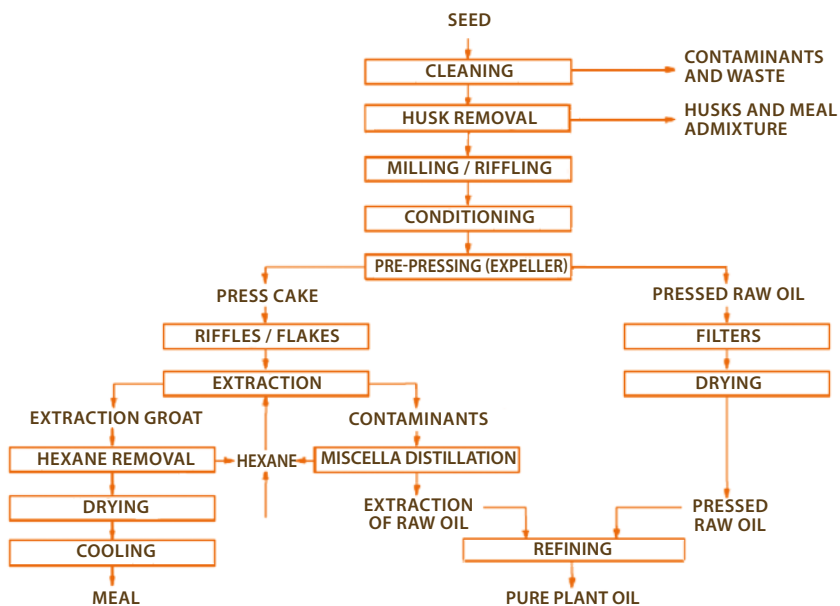

Figure 1 Seed processing in a decentralized oil mill

Figure 2 Seed processing in a (centralized) industrial oil mill



that rapeseed oil fuel is stored at a constantly low temperature between 5 and 10°C and in darkness, for example, by storing in an underground tank. Water must not be allowed to enter the tank, either through precipitation or condensation, and contact with air should be minimised, for example, by reducing the areas of contact. Rapeseed oil fuel which needs to be stored should also be as free as possible from contaminants so that enzymatic degradation of the oil is prevented and there is no accumulation of dirt through sedimentation at the bottom of the tank. With respect to the materials of which the tank is made, steel and stainless steel are both suitable, and with restrictions, synthetic materials such as high density polyethylene (HDPE). Metals such as copper and its alloys which may have a catalytic effect must be avoided at all costs. Containers made of synthetic materials not opaque to light should only be stationed in a dark environment. The storage container must be capable of being firmly closed to prevent the ingress of water. Steps should be taken to avoid the formation of condensation while filling the tank or during storage, which may occur because of large temperature differences between the air in the tank and its contents. If necessary, the tank ventilation should be fitted with a filter to prevent water entering the tank. Underground tanks are preferable to overground tanks because they are better at maintaining

a constant temperature. Storage tanks must be regularly cleaned. Only completely dry tanks may be refilled with rapeseed oil fuel.

With very good storage conditions, a qualitatively high-value pure plant oil with a low level of polyunsaturated fatty acids may be safely stored for up to twelve months. In unfavourable conditions such as outside storage and exposure to changing levels of sunshine and temperatures, the oxidation stability could fall below the requirements of the norm DIN 51605 within three months.

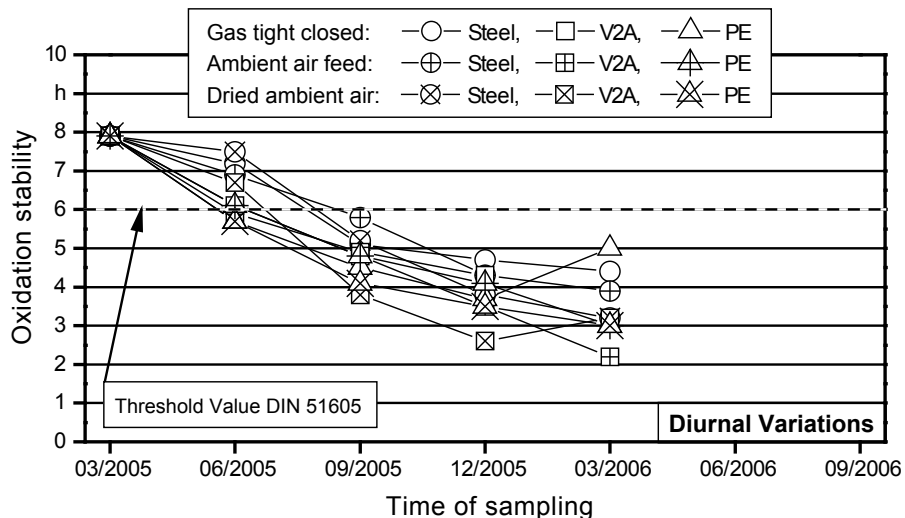
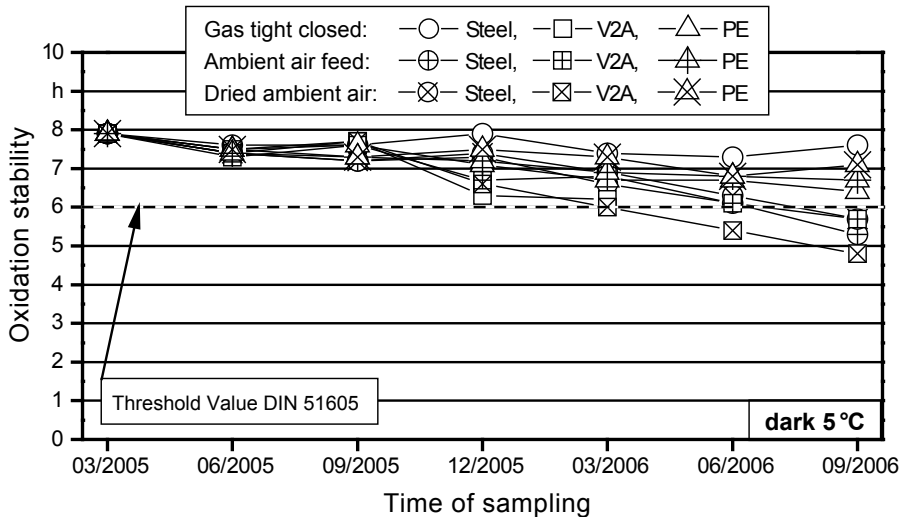

Figure 3
Oxidation stability (DIN EN 14112) of rapeseed oil fuel samples exposed to varying storage conditions with unprotected outside storage

Figure 4
Oxidation stability (DIN EN 14112) of rapeseed oil fuel samples exposed to varying storage conditions with light-protected storage and a temperature of 5°C



THE PROPER STORAGE OF PURE PLANT OILS

JOSEF RATHBAUER

BLT - Biomass | Logistics | Technology
Francisco Josephinum
Wieselburg (Austria)

In general, the storage of pure plant oil is also covered by a duty of care.

- Storage should be in containers which are approved by the manufacturers for this purpose.
- In the case of above-ground storage, the containers should be located on solid ground impermeable to liquids.
- The tank must be provided with a bund or suitable secondary containment capable of containing the total contents of the tank.
- In the case of underground storage, the tanks should be double-walled.
- In the case of outdoor storage, the container must be roofed over.

- An impermeable metal bund should be installed below the fuelling area. Binding agents (e.g. sawdust or other compostable material) should be available in the proximity of the installation. Spilled oil creates a slipping hazard.
- If there is a flow of waste water near the installation, a collection sump with a gravity separator (fat separation) should be provided. The collected material can be composted.

Because of the special properties of pure plant oil, the project organiser may apply to the authorising body for a relaxation of some requirements but would need to provide justification.

For both the storage of oil seeds and the oil itself, particular parameters need to be observed in order to protect the quality of the product. Proper storage is an important precondition to ensure the trouble-free operation of the engine.

Because pure pure plant oil is a natural product, it is subject to specific ageing changes and chemical reactions. Adverse influences and their effects include the following:

<i>Adverse influence</i>	<i>Effect</i>
Oxygen	Oxidation
Water	Hydrolysis
High temperatures	Oxidation, hydrolysis
Light	Oxidation
Metals (Cu, Fe)	Catalysts for oxidation



There are measures which can be taken to deal with the above-listed possible chemical reactions for the proper storage of oils and oils seeds.

Measures for the storage of oil seed:

- Higher stage of maturity
- Lower moisture level
- Reduced level of foreign objects
- Low storage temperatures with sufficient ventilation

Measures for the proper storage of pure plant oil:

- Low level of contamination
- Low storage temperatures but frost-free
- Avoidance of temperature fluctuations
- Protection from light
- Avoidance of the presence of oxygen and water
- Avoidance of non-ferrous metals
- Storage tanks should be capable of being completely emptied and properly cleaned.
- Regular tank cleaning is recommended

To avoid getting condensation water in the tractor tank, the tank should always be full if possible.

For example, it is better to fill up in the evening when the work is finished than to wait until the following morning!

Fuel intake points should not be set low in the tank as this is where sediments can collect.

Pure plant oils have different shelf lives according to the storage conditions and oil quality. However, even with favourable conditions, the oil should not be stored for longer than a year.



RAPESEED CAKE AS A FEEDSTUFF FOR FARM LIVESTOCK

ANDREA MEYER

Landwirtschaftskammer Niedersachsen
Hannover (Germany)

*Feeding value of rapeseed
cake (UFOP-Monitoring, 2006,
basis 90% DM)*

Rapeseed cake is mainly used as a protein feed for cattle but is equally of value in the feeding of pigs. Its use is also permitted in farming enterprises which operate under EU environmental directives. In setting the proportion of rapeseed cake in the ration, the fat and glucosinolate contents are of particular significance. Glucosinolates are mustard oil compounds which at higher levels may have negative effects on the feed intake and the thyroid function. They become enriched in rapeseed cake through the fat removal process. Because there is no thermal post-treatment, rapeseed cake contains about twice as much glucosinolates as rapeseed meal. The fat content can vary greatly according to the extraction process and oil content of the rapeseed. In an investigation by the UFOP, the average fat content was 14.4% with a range of variation from 8.4% to 19.8%. The raw protein content

showed a similar variation with about 26% to 31% and the energy content also varied.

For use with dairy cows, rapeseed cake is of interest particularly because of the high level of utilisable raw protein and energy. The key factor in setting the amount of rapeseed cake in the ration is not the glucosinolate content (at about 5 mmol/kg feedstuff, cattle tolerate much more than pigs) but the fat content. This should not exceed 4% - 5% dry weight of the total ration, allowing feed quantities of about 2 - 2.5kg per day, according to fat content. Rapeseed cake at these levels has a positive effect on the spreading quality of the butter. For young cattle, up to 1kg is recommended and for calves, up to 0.5kg per day. Rapeseed cake is one of the feedstuffs richest in amino acids with a lysine content of 15g - 16g per kg and methionine+cystine at 11g - 13g. Restrictions in use for fattening pigs arise mainly from the glucosinolate content and in part from the fat content, as a high level of polyunsaturated fatty acids can cause deterioration of the bacon quality. For pigs, a maximum glucosinolate content of 1 - 2 mmol/kg in mixed feed is recommended. In following this restriction, up to 10% rapeseed cake can be used in pig feed. When using rapeseed cake, care should be taken to ensure that a sufficient amount of iodine is added.

34 samples		Average value	From - to
Dry mass	%	91.4	89.7 - 92.9
Raw protein	g/kg	284	258 - 313
Raw fat	g/kg	144	84 - 198
Raw fibre	g/kg	108	97 - 117
Glucosinolates	mmol/kg	15.6	9.3 - 21.1
ME (pig)	MJ/kg	13.2	11.8 - 13.4
NEL	MJ/kg	7.7	7.2 - 8.3
nXP	g/kg	192	188 - 197
RNB	g/kg	12	11 - 20

PURE PLANT OIL QUALITY DIN 51605

“FUELS FOR PPO COMPATIBLE COMBUSTION ENGINES - FUEL FROM RAPESEED REQUIREMENTS AND TEST METHODS”

EDGAR REMMELE

Technologie- Förderungszentrum (TFZ)
im Kompetenzzentrum für
Nachwachsende Rohstoffe
Straubing (Germany)

In September 2010, the German Institute for Standardisation published norm DIN 51605: “Fuels for vegetable compatible combustion engines - fuel from rapeseed - requirements and test methods”. This updated norm replaced the pre-standard DIN V 51605 which had been valid since July 2006. In the process of updating the pre-standard to the current norm, particular attention was given to the increasing demands of pure plant oil compatible diesel engines with modern exhaust gas aftertreatment systems.

Ever stricter legal limits on exhaust gas emissions have meant that engine emissions have to be reduced using methods outside of the engine. Examples of this in use include the oxidation catalyst, selective catalytic reduction (SCR) and the particle filter. However, the effectiveness of exhaust gas catalysts is reduced through the presence of phosphorus in the exhaust fumes. Calcium and magnesium in the fuel result in ash deposits in the particle filter which leads to increasing exhaust gas back-pressure. In order to guarantee the functional effectiveness of exhaust treatment systems also when rapeseed oil fuel is used, the threshold limit for phosphorus has been set at 3.0 mg/kg and the threshold limit for both calcium and magnesium at 1.0 mg/kg. Because the previously laid down methods of analysis were not capable of achieving the required precision with re-

spect to the new threshold values, a new test method was developed and assured via interlaboratory testing. This is DIN 51627-6: “Direct determination of trace elements in pure plant oils by inductively coupled plasma optical emission spectroscopy (ICP OES)”. The new threshold values for phosphorus, calcium and magnesium come into force on 1 January 2012, at the same time that tractors with a power rating of between 56 and 130 kW will be subject to EU exhaust emission regulation stage IIIB.

The new DIN 51605 has set the course for the use of rapeseed oil fuel in pure plant oil compatible engines with exhaust gas aftertreatment systems of the latest generation.

Because DIN 51605 applies only to the use of pure plant oil fuel made from rapeseed oil, the German Institute for Standardisation is working on a pre-standard DIN 51623 for pure plant oil fuels which will allow oleaginous parts of plants to be used as a raw material without further restriction. In comparison to DIN 51605, additional requirements such as with regard to the levels of waxes which may be found in sunflower oil should be considered.

The standards DIN 51605 and DIN SPEC 51623 can serve as the basis for European standardisation activity at CEN. The norms are available from the publisher Beuth Verlag, Berlin under www.beuth.de.

PURE PLANT OIL QUALITY AND THE CEN WORKSHOP AGREEMENT

GEORG GRUBER

Vereinigte Werkstätten
für Pflanzenöltechnologie - VWP
Allersberg (Germany)

The basis of the European Norms and Standards Organisation (CEN) workshop - WS 56 - is the project 2nd Generation VegOil which is supported by the EU. Here, the tractor manufacturer J. Deere with its plant oil engine developing partner VWP as well as other partners test the use of various pure plant oils (rapeseed oil, sunflower oil, oil of *Camelina sativa*, maize germ oil and jatropa oil) in modern common rail engines at the various emissions standards (TIER 3a, TIER 3b, TIER 4). The necessity of establishing a European norm arises from guarantee issues affecting international companies where engine manufacturers want to sell pure plant oil engines using fuels other than rapeseed oil in other countries.

As well as the extension of the standard DIN V 51605 and now DIN 51605

to the EU level and the inclusion of other pure plant oils in the standard, the CEN-WS 56 initiative is also concerned with specifications for automotive fuel quality based on the most up-to-date engine technology.

Testing carried out by John Deere and VWP at the University of Rostock have in particular shown

the negative effects on the engines and especially on modern exhaust aftertreatment systems such as catalytic converters and particle filters resulting from the presence of phosphorus, alkalis and alkaline earth metals. Based on the results of DIN V 51605, DIN 51605 and DIN SPEC 51623 for rapeseed oil as well as the biodiesel standard EN 14214, two quality standards for different pure plant oils are being prepared at European level.

The first quality standard with lower requirements is aimed mainly at older diesel engines not having exhaust gas treatment systems. A second quality standard will provide for the removal of phosphorus, alkalis and alkaline earth metals to achieve an analytical maximum limit (about 1 mg/kg per element of P, Ca and Mg). Both quality standards will take into account sustainability criteria and also a new viscosity index featuring the starting point of the engine operation is highlighted.

In addition, the use of additives (e.g. to improve storage stability) is being examined because particularly in the case of imported pure plant oils, a reduction in quality through storage and long transport routes can be expected.

In the formulation of the specifications, consideration will also need to be given that decentralised oil mills are also capable of manufacturing to the required oil quality.



OPPORTUNITIES FOR USING PURE PLANT OIL AS A FUEL IN ENGINES

KURT KRAMMER

BLT - Biomass | Logistics | Technology
Francisco Josephinum
Wieselburg (Austria)

GÜNTER BARTEN

Projektorganisation Regionale
Ölpflanzennutzung
Eschweiler (Germany)

Biogenic fuels will in future increase in importance as a consequence of political objectives at European level. Fuels based on pure plant oils will play a special role here. At present in most of the countries of the European Union, fatty acid methyl esters are added to fossil diesel.

Pure plant oil has significantly different properties to fossil diesel. In **table 1**, the main differences between diesel, rapeseed oil and RME (biodiesel) are shown.

The specific calorific value of pure plant oil in MJ per kg is about 10% lower than in diesel fuel because of the oxygen content. However, when one considers the higher specific gravity of pure plant oil, the difference in calorific value per litre of rapeseed oil compared to fossil diesel reduces to approximately 3%. This energy content of the fuel is responsible for the efficiency and consumption behaviour. With a comparable thermal efficiency, rapeseed oil shows a lower efficiency loss or increased consumption compared to diesel. However, the higher oxygen content and the almost complete absence of

sulphur in rapeseed oil is beneficial for its combustion. The energy content of a litre of rapeseed methyl ester is slightly below that of rapeseed oil because of the lower specific gravity.

The greatest difference between diesel and pure plant oil, however, is in the viscosities. In **figure 1**, the different viscosity behaviours are shown for rapeseed oil, diesel and RME.

The curves clearly show that it is only at high temperatures (90°C) that the viscosity of rapeseed oil approaches the viscosity of diesel at 20°C. This leads to cold start problems when rapeseed oil is used as a fuel and in addition, to a deterioration in the atomization behaviour during fuel injection.

In various projects, it has been shown that with the use of pure plant oil in direct injection engines, even after a relatively short duration, problems may occur. A build-up of deposits in the combustion chamber and damage to the injectors have been found. For the use of pure plant oil in diesel engines, several possibilities may be considered:

- Adapting the fuel to the engine
- Adapting the engine to the fuel
- Using an admixture of rapeseed oil or RME with fossil fuels

ADAPTING THE FUEL TO THE ENGINE

The most widely used procedure for adapting rapeseed oil as a fuel for conventional diesel engines is through transesterification to rape methyl ester. In this

Table 1

Properties of diesel, rapeseed oil and RME

	Unit	Diesel	Rapeseed oil	RME
Calorific value	MJ/kg	42.4	37.6	37.2
Specific gravity at 20°C	kg/l	0.83	0.91	0.88
Calorific value (Vol.)	MJ/l	35.2	34.2	32.7
Viscosity at 20°C	mm ² /s	5	70	7.2
Flash point	°C	>55	>220	>110
Combustibility	CN	>51	-	>51

process, the triglycerides in the rapeseed oil are replaced with mono-alkyl esters with the help of catalysts (e.g. sodium or potassium hydroxide). In most cases, methanol is used. Glycerol is produced as a byproduct. This and the resulting RME must be subject to further treatment before use as a fuel.

In principle, almost all pure plant oils can be esterified. As well as vegetable fats, waste cooking oil and animal fats can also be used as a raw material. The general term applied to the resulting product is biodiesel. This is used as a synonym for fatty acid methyl ester (FAME). The standard EN 14214 regulates the requirements for this fuel.

ADAPTING THE ENGINE TO THE FUEL

For the use of pure pure plant oil as a fuel, it is necessary to adapt the combustion technology of the diesel engine to be compatible with the properties of the pure plant oil. In agriculture, there have been engines around for several years now which are manufactured to be able to operate on 'natural pure plant oil', (for example, John Deere, Fendt, Deutz). In most cases, however, existing diesel engines have to be converted to be able to operate on the fuel.

In the process of converting an engine, adaptations may need to be made to the fuel lines, combustion chamber and fuel injectors. Each concept has to be specific to the characteristics of the particular engine and the conversion concepts of the various suppliers of such services may vary considerably in quality and performance. The actual conversion measures themselves are often commercial secrets. Basically, there are two types of conversion, the single-tank and two-tank systems.

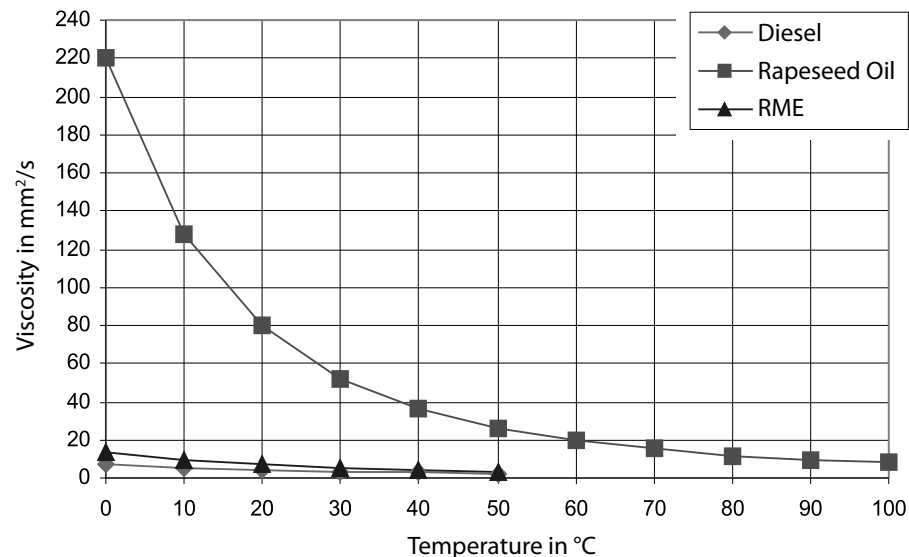

Figure 1 Viscosity behaviours of rapeseed oil, diesel and RME (Krammer, 2000)

SINGLE-TANK SYSTEMS

In the single-tank system, the vehicle is adapted to operate only on rapeseed oil. Often, fuel lines with wider diameters are fitted and catalytic materials such as copper and brass are not used. In most cases, a fuel pre-heater is also installed and this may be operated with electrical power or in the form of a cooling system heat exchanger. Where the vehicle is operated with different fuels, a fuel recognition system may be in place. In order to improve the cold-start characteristics, it may be necessary to install an auxiliary heating system. Cold-starting can also be improved by modifications to or replacement of the glow plugs as well as extended pre-glow and after-glow times. In one system, the injector nozzles are also heated in order to reduce the viscosity of the pure plant oil and to optimise the injection process. In a small number of conversions, the injector pump is replaced as some types are not suitable for use with pure plant oil.

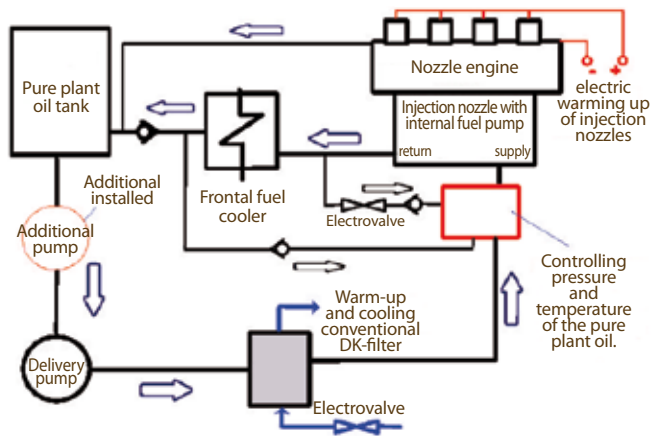

Figure 2 Conversion concept offered by the company Hausmann - single-tank system

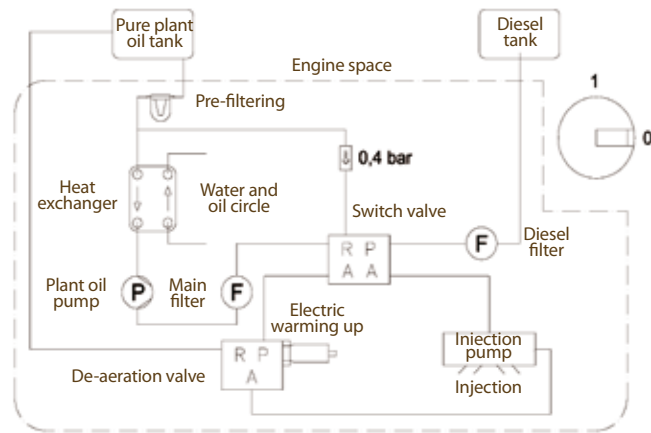

Figure 3 Conversion concept of the company Jedinger

The greatest advantage of the single-tank system is certainly that the whole diesel storage system is no longer necessary. As part of an Austrian research project 'rape-seed oil as a fuel alternative in agriculture', various conversion systems were investigated. In the case of the single-tank system, there are far few companies offering this type of conversion. The costs of such systems are in the region of € 5,000 to € 8,000 (excluding VAT).

TWO-TANK SYSTEMS

Two-tank systems make it possible to operate an engine with pure plant oil in a system using two types of fuel. When starting and switching off the engine, normal diesel is used for a short period. This means that after operating with pure plant oil, the engine is switched over to run on diesel in order to flush the injectors and so that the next start is again with diesel. Otherwise the engine will run at optimal conditions on pure plant oil, though at low engine

loads, some systems can be switched back to diesel mode. Further modifications to the engine are not necessary. The costs for a two-tank conversion for a tractor vary between about € 4,000 to € 6,000 (excluding VAT).

The advantage of a two-tank system is that there are normally no cold-start problems in winter as the engine is started with diesel. However, a dependency on the use of fossil diesel is still present and the ecological advantages of using pure rapeseed oil are reduced.

Not every engine is equally suitable for operation with pure plant oil, so it will be necessary to give careful consideration to the experience of the company providing the service when making a decision.

USING AN ADMIXTURE OF PURE PLANT OIL WITH FOSSIL DIESEL

A number of studies were carried out, particularly in the early 1980s, on the use of

admixtures of pure plant oils with fossil diesel. Short-time tests with these fuel mixes were almost always successful. Long-time tests on the other hand resulted in engine breakdown because of the build-up of deposits and carbonisation.

This mainly occurred when the amount of pure plant oil was greater than 20%. It was estimated, for example, that in the case of a 20% admixture of rapeseed oil, the lifetime of an engine would be reduced to about 80% of the expected functionality time for diesel (Maack und Maurer, 2002).

However, the question as to whether rapeseed oil will be used in diesel engines is mainly dependent on the economic conditions.

A certain difference between the prices of diesel fuel and rapeseed oil is necessary to cover the costs of the conversion and any possible additional expenses (e.g. shortened engine oil change intervals, installation of an on-site fueling point etc.).

TECHNICAL SOLUTIONS

FUELS FOR COMMERCIAL VEHICLE ENGINES

SOLUTIONS FOR AGRICULTURAL MACHINES

STEFANIE DIERINGER
PETER PICKEL

John Deere
European Technology Innovation Center
Kaiserslautern (Germany)

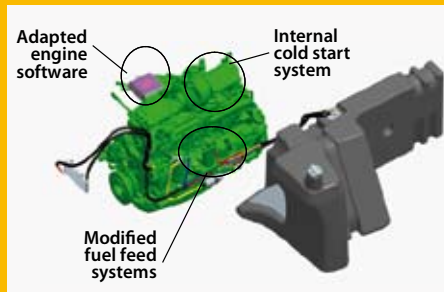

Figure 1
The concept of the John Deere pure plant oil engine

Figure 2
The results of the 8-mode test for different fuels

With the help of publicly funded projects (FNR FKZ 22014905, EU FP7-219004), a single-tank system operating on pure plant oil fuels could be developed and optimised. This has been tested between 2008 and 2011 on stage IIIA tractors in a trial taking place across the European Union using selected farmers. In the trial, other pure plant oils were used as well as rapeseed oil - sunflower oil, jatropha oil and cameline oil. The main thrusts of the European Union '2nd Generation Pure plant oil project are the parallel developments of both engine technology regarding current and future exhaust emissions standards and a decentralised production process for cold-pressed pure plant oils. These pure plant oil fuels of the second generation comply with considerably stricter threshold values for levels of phosphorus, calcium and magnesium, and additionally for potassium and sodium, than are stated in the current DIN 51605. As well as the high fuel quality, the opportunities for decentral use of these production and processing methods is at the centre of the development work: the process must remain 'agriculturally-compatible' and the method of cold-pressing must not be significantly modified.

Figure 1 shows a schematic diagram of the necessary engine modifications for running on pure plant oil. In order to allow for the higher viscosity of pure plant oil fuels, the performance of the fuel delivery system is increased and for cold-starting, a pre-heater is installed which enables starting with 100% pure plant oil at temperatures down to 0 °C.

The most important means of achieving compliance with the performance and emissions targets is the adaptation of the engine control unit. In this way, the stage IIIA emissions standards can be achieved for all the above-mentioned oils. The results of this for the so-called 8-mode non-road steady cycle under 97/68/EC (NRSC) are shown in **figure 2**. The same engine control unit software could be used for all pure plant oil fuels.

An available option was to fit the engine with a retrofit diesel particle filter (DPF). Its function was not negatively affected by the use of pure plant oil fuel thanks to the high fuel quality.

Subsequent to the investigations on the stage IIIA engine, the research and development work with a stage IIIB engine was continued. The first results also show that for this engine with DOC/DPF systems fitted as standard, the higher threshold values for stage IIIB can be achieved with pure plant oils.

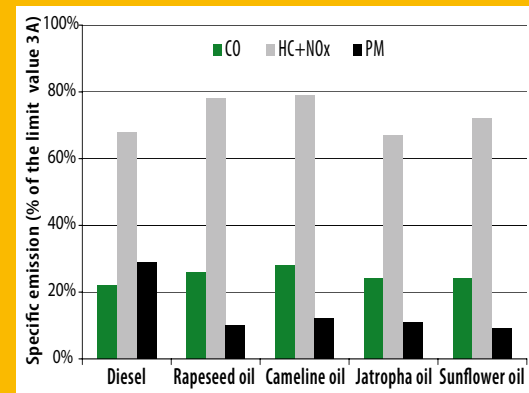

THE ECONOMIC VIABILITY OF TRACTOR CONVERSIONS

JOSEF BREINESBERGER
 AGRAR PLUS GmbH
 St. Pölten (Austria)

The economic viability of converting tractor engines is dependent for the most part on three factors: the costs of conversion, the price difference between pure plant oil and diesel, the annual fuel consumption (independent of the efficiency of the tractor and the annual operating durations). The examples given here are based on a gross calculation which assumes an averaged use for most farmers.

The following assumptions were made for the calculation:

- For the fuel consumption, a medium workload was used based on the ÖKL (Austrian board for technical and rural development) figures for fuel consumption in 2011.
- In the case of the two-tank system, the engine is started and switched off running on diesel. The diesel consumption was assumed at 10% of the total fuel use. Of course, this value differs accord-

ing to how often the tractor engine is switched on and off.

- The additional consumption for rapeseed oil was assumed to be 2%. This figure arises from the different energy content compared to diesel. The specific calorific value for diesel is about 42 MJ/kg and about 38 MJ/kg for rapeseed oil. However, in consideration of the density, which is higher for rapeseed oil, and the calorific value per unit of volume, the loss in calorific value for rapeseed oil in the calculation is reduced to about 2%.
- In respect of the engine oil costs, no allowance was made for shorter service intervals because several studies have shown that in the use of pure plant oils meeting the norm standards, a reduction is not absolutely necessary. Furthermore, based on this point, no increased service costs are added.
- A figure of 6% was used for the interest rate calculation (from ÖKL guideline values for machine running costs, 2011).

As the results of the calculation show, the conversion of an 80 kW tractor pays for itself after 1.9 - 5.5 years (according to conversion costs, fuel price differences and hours of operation). For a 120 kW tractor, this figure is down to between 1.3 and 3.7 years because of the higher fuel consumption.

The cost savings made by converting to pure plant oil fuel amount to between € 583 and € 3,247 per year for the examples shown in the table.

Tractor conversion	Single-tank system € 7,000		Two-tank system € 5,000	
	€ 0.20	€ 0.30	€ 0.20	€ 0.30
Tractor 80 kW	<i>700 operating hours per year</i>			
Payback period in years	5.5	3.5	4.3	2.8
	<i>1000 operating hours per year</i>			
Payback period in years	3.8	2.4	3.0	1.9
Tractor 120 kW	<i>700 operating hours per year</i>			
Payback period in years	3.7	2.3	2.9	1.9
	<i>1000 operating hours per year</i>			
Payback period in years	2.6	1.6	2.0	1.3

HAUSRUCKÖL AN EXEMPLARY MODEL OF A DECENTRALISED OIL MILL

The Hausrucköl oil mill started production in August 2006 under the name Hausrucköl Verein & CoKG. This farm cooperation project was an initiative of the machinery rings of the communities Grieskirchen, Waizenkirchen and Schwanenstadt. The idea behind the project was that the members of the machinery rings, in which farmers have set up a self-help establishment, would benefit from a shared and centrally-controlled oil mill. In this way, it was ensured that the mill would be large enough to assure a viable operation. At the same time, the presence of a plant operator with the required know-how means that quality assurance can be maintained.

The project started with the founding of an association which today has about 340 members. These members ensure

the availability of the necessary area of rapeseed cultivation (about 500 ha). For the location, the agricultural enterprise of one of the members was selected and the mill was constructed as a new installation. It is set up to process up to 3,800 tonnes of rapeseed and sunflower. This corresponds to a production output of about 1.45 million litres of pure plant oil and about 2,350 tonnes of press cake. To provide sufficient storage capacity, a store with a capacity for 2000 tonnes of rapeseed was built by the farmer. The regional storehouses and the agricultural product traders take the remaining rapeseed.

The objective of the members is that as well as the production of pure plant oil for use in partially converted tractors, they can produce their own protein animal feed for livestock farming.



In the meantime, an additional income source has developed for the rapeseed oil through a cooperation with a cooking oil supplier, forming the basis of the marketing of the product in Austria which meets the AMA seal of quality.

In the federal state of Upper Austria, oil mills have been set up by machinery rings across the whole area based on the same organisational set-up.

Further information about this can be obtained by emailing hausruckoel@maschinenring.at or via the website: www.maschinenring.at/grieskirchen.

WHERE YOU CAN GET INFORMATION

AGRAR PLUS Ges.m.b.H.

Bräuhausgasse 3
A 3100 St. Pölten
Tel. +43(0)2742/352234
Fax +43(0)2742/352234 4
office@agrarpplus.at
www.agrarpplus.at

Bundesverband Pflanzenöl Austria

Bräuhausgasse 3
A 3100 St. Pölten
Tel. +43(0)2742/352 234
Fax +43(0)2742/352 234 4
office@pflanzenoel-austria.at
www.pflanzenoel-austria.at

Bundesverband Pflanzenöle e.V. (BVP)

Quenteler Straße 19
D 34320 Söhrewald
Tel. +49(0)5608/35 24
Fax +49(0)5608/958 79 91
info@bv-pflanzenoele.de
www.bv-pflanzenoele.de

Vereinigte Werkstätten für Pflanzenöltechnologie (VWP)

Am Steigbühl 2
D 90584 Allersberg-Göggelsbuch
Tel. +49(0)9174/97707-11
Fax +49(0)9174/971768
g.gruber@vwp-europe.com
www.vwp-europe.com

Technologie- und Förderzentrum (TFZ)

im Kompetenzzentrum für Nachwachsende Rohstoffe
Schulgasse 18
D 94315 Straubing
Tel. +49(0)9421/300-210
Fax +49(0)9421/300-211
poststelle@tfz.bayern.de
www.tfz.bayern.de

BLT - Biomass | Logistics | Technology

Rottenhauserstr. 1
A 3250 Wieselburg
Tel. +43(0)7416 52175-0
blt@josephinum.at
blt.josephinum.at

AIEL – Italian Agriforestry Energy Association

V.le dell'Università, 16
I 32020 Legnaro (PD)
Tel. +39(0)49 88 30 722
francescato.aiel@cia.it
www.aiel.cia.it

Fachagentur Nachwachsende Rohstoffe e.V. (FNR)

Hofplatz 1
D 18276 Gülzow-Prüzen
Tel. +49(0)3843/6930-0
Fax +49(0)3843/6930-102
info(bei)fnr.de
www.fnr.de
www.bio-kraftstoffe.info

PPO.eu

H. Aberson
Alteveersweg 42
NL 8392 MS Boijl (frl.)
Tel. +32(0)561/421104
info@solaroilsystems.nl

WWW

Bundesverband Dezentraler Ölmühlen e.V.

Hofgut Harschberg
D 66606 St. Wendel
Tel. +49(0)6851/802 48 29
Fax +49(0)6851/802 48 22
info@bdoel.de
www.bdoel.de

PPO.be vzw

Martina Hülsbrinck
Dongelsplein 13
B 3018 Leuven
Tel. +32(0)16 20 48 18
Fax +32(0)494 70 56 50
www.ppo.be

REGIOOEL

Projektorganisation
Regionale Oelpflanzennutzung
Günter Barten
Merzbrücker Str. 31
D 52249 Eschweiler
Tel. +49(0)2403/942 4085
Fax +49(0)2403/942 4084
regiooel@arcor.de
www.regiooel.de

Verband der Deutschen Biokraftstoffindustrie e.V.

Elmar Baumann, Geschäftsführer
Am Weidendamm 1A
D 10117 Berlin
Tel. +49(0)30/72 62 59 11
Fax +49(0)30/72 62 59 19
info@biokraftstoffverband.de
www.biokraftstoffverband.de

UFOP

Union zur Förderung von Oel- und Proteinpflanzen e.V.
Haus der Land- und Ernährungswirtschaft
Claire-Waldoff-Str. 7
D 10117 Berlin
Tel. +49(0)30/31 90 42 02
Fax +49(0)30/31 90 44 85
info@ufop.de
www.ufop.de

Verband der Ölsaatenverarbeitenden

Industrie in Deutschland e.V.
Am Weidendamm 1A
D 10117 Berlin
Tel. +49(0)30/726 259 00
Fax +49(0)30/726 259 99
info@ovid-verband.de
www.ovid-verband.de/

FEDIOL

168, Avenue de Tervuren
B 1150 Bruxelles
Tel. +32(0)2 771 53 30
Fax +32(0)2 771 38 17
fediol@fediol.eu
www.fediol.org/

C.A.R.M.E.N. e.V.

Schulgasse 18,
D 94315 Straubing
Tel. +49(0)9421/960-300
Fax. +49(0)9421/960-333
contact@carmen-ev.de
www.carmen-ev.de



Editorial coordination
Reent Martens, 3N e.V. (Germany)
Eliseo Antonini, AIEL (Italy)

Translation
Les Reay (Germany)

Pictures
3N e.V. Archive, AIEL Archive, Josef Voraberger (page 33)

Supported by
Agriforenergy II – IEE/08/600

Graphic designer
Marco Dalla Vedova

Printed in October 2011
Copyright © 2011

*The sole responsibility for the content of this publication lies with the Authors.
It does not reflect necessarily the opinion of the European Communities.
The European Commission is not responsible for any use that may be made
of the information contained therein.*

PARTNERS OF AGRIFOREENERGY II

Styrian Chamber of Agriculture and Forestry (Coordinator)
www.lk-stmk.at

Slovenian Forestry institute
www.gozdis.si

Italian Agriforestry Energy Association
www.aiel.cia.it

Energy Agency for Southeast Sweden
www.energikontorsydost.se

Technical Research Centre of Finland
www.vtt.fi

Council of the Bulgarian Agricultural Organisations
www.cbao-bg.com

European Biomass Association
www.aebiom.org

3N e.V.
www.3-n.info

This document can be downloaded at www.agriforenergy.com